

S2.S3 Instruction Manual

Important Safety Information

This product has been designed and manufactured to assure personal safety. Safety is essential in the use and maintenance of the equipment. Please read and observe all warnings instructions given in this operation manual. Keep this manual available to all personnel.



Warning **Caution**

- 1 Do not disassemble or lubricate any parts of the cleaver. Doing so could cause serious damage to the cleaver.
- 2 This is a precision instrument. Do not impact the cleaver by hitting or dropping it. Doing so may cause personal injury and loss of cleaving performance. Handle with care.
- 3 Glass fiber fragments are extremely sharp. It will result in injury if fragments come into fingers or eyes. Handle with care. Wear safety glasses at all times during cleaving operation for protection from glass fibers.
- 4 Collect all fiber scraps in the dust bin and dispose of them in an approved fiber disposal unit.
- 5 The blade of the cleaver is extremely sharp. Do not touch it with bare hands.
- 6 Do not impact the top clamp lever. Doing so could cause damage to the cleaver and loss of cleaving performance.
- 7 Stop using the equipment if the cleaver is damaged or a problem occurs. Do not disassemble or refit the unit. Contact our maintenance service center.

Request of using authentic optical fiber cleaver blade OMB/OMC0824013-01A

To ensure the quality and performance of S2.S3, only if users utilize appropriate replacement blade, can users rotate the blade without adjust the blade pressure.

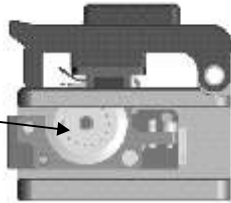

blade locking screw

S2. S3

Caution1: If users utilize replacement blade which is not designed for optical fiber cleaver, possibly users are unable to replace the blade or adjust the blade pressure. S2.S3 utilize appropriate blade locking screws. Users do not need to adjust the height of blade after rotating the blade.

So it is possible that other kinds of replacement blades can not be installed. Besides, crews of blade pressure adjustment crews (in the red circles below) are matched with the accuracy of the appropriate replacement blade. If users utilize replacement blade provided by other factories, possibly the height of blade cannot be adjusted.

Caution2: If users utilize the replacement blade which is not designed for optical fiber cleaver, quality and performance are not guaranteed.

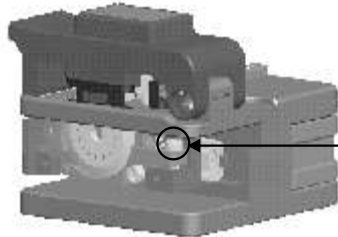

Blade pressure adjustment crews

1 General

Specifications

S2.S3	
Cladding Diameter	125μm
Fiber Size	Single fiber (Φ0.25&0.9mm) Up to 12-fiber ribbon-2.5 Leather cable
Cleaved Length	18mm
Dimensions(H×W×D)	S2.S3: 60(W) x 59.5(D) x 52(H)mm
Weight	S2.S3: about 225g

Included parts

S2.S3		
Optical Fiber Cleaver S2.S3	1 pc	Single fiber adapter: AP-S2.S3
Carrying case	1 pc	Replacement blade: SKLP-20BL/12 pieces
Instruction Manual	1 pc	SKL-22BL/16pieces

2. Structure

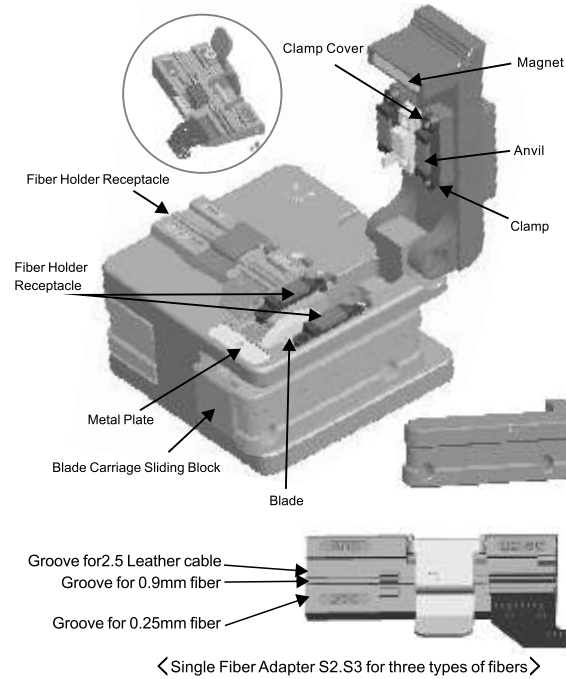

3. Operations

S2.S3 series

1: Open the clamp cover lever and fiber holder lid. The blade carriage should be in the forward position.

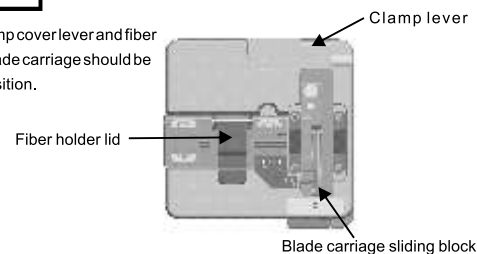

2: Lower the fiber straight into the groove with the end of the fiber coating (e.g. if the cleave length is 18mm) at the 18mm mark on the ruler. Make sure the fiber lies straight across both rubber pads.



3: Close the lid of the single fiber adapter and clamp the fibers.

4: Close the clamp cover and lower the top clamp lever. Slide the blade carriage to the rear of the cleaver. The fiber will be cleaved.

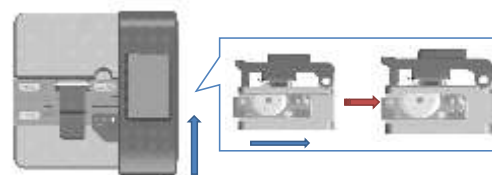

Open the top clamp lever and clamp cover. Press the coating fiber and open the lid of the single fiber adapter at the same time. Lift the newly cleaved fiber. Lift the off-cut and dispose it properly.

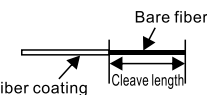

4. Maintenance

Cleaning

To keep excellent cleaving quality, cleaning must be performed after use. Clean the blade edge, the rubber pad of the clamp and the anvil with a cotton swab moistened with isopropyl alcohol.

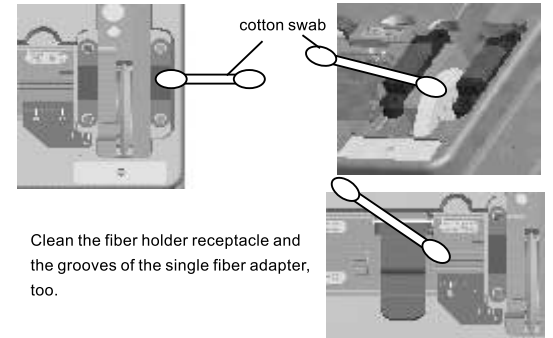

Clean the fiber holder receptacle and the grooves of the single fiber adapter, too.



Caution

- Dust on the blade edge or the clamp might cause loss of cleaving performance or poor quality of fiber end face.
- Do not clean them with any other kind of chemicals.
- If the top clamp lever is closed leaving an off-cut fiber on the clamp, the rubber pad of the clamp will have a trace of the fiber, causing loss of cleaving performance or poor quality of fiber end face.

Blade position change

As the number of the cleaver's increases, a symptom that fiber cannot be cleaved or cracks will occur. If such symptom continues to appear, the blade position is worn out.

Rotate the blade according to the following procedures and use a new blade position

[Reference] 1,000 fibers per position

1: Remove the right trim cover with a cross screwdriver.

2: Use a slotted screwdriver to loosen the blade setscrew.

3: Rotate the blade to the next position by pressing its side or edge with a cotton swab.

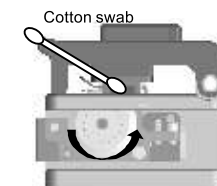

Rotate the blade in the direction indicated by the arrow



Caution

- Do not rotate the blade with bare hands.
- Do not rotate the blade with metallic tweezers. Doing so may damage the blade.

4: Tighten the blade setscrew.

[Reference] Optimum torque: Approx. 0.98N.m (10kgf.cm)

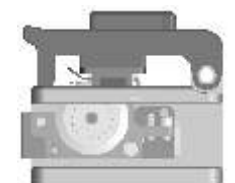

Caution

- Do not over-tighten the blade setscrew. The screw will get down out.

- 5: Try and cleave the fiber. Make visual check of the fiber end face with the splicer. If the fiber end face is poor, adjust the blade height. (Refer to "Blade height adjustment.")
 6: After adjusting the cutting Angle to level off and having a good welding effect, lock the right trim cover.

Blade height adjustment

(0: S2, S3 series, remove the right trim cover first.)

- 1: Loosen the 2 cross head screws.

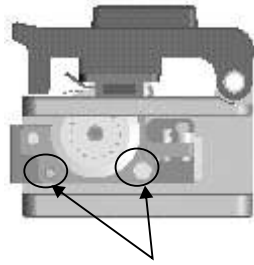

- 2: Loosen the blade height locking screw.

Blade locking screw

use Hexagonal Wrench

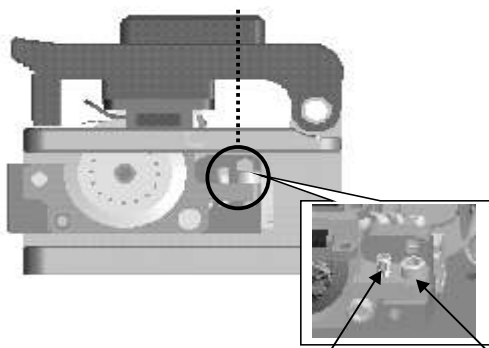

Blade height adjustment screw (adjustment screw) Blade height locking screw

- 3: Place a mechanical pencil lead or a light stick on the clamps. Slide the blade carriage back and forth and turn the blade height adjustment screw.

The point where the lead barely touches the edge of the blade is a reference point(0 μ m).

☑ Tips

- To make the blade higher, loosen the blade height locking screw and then turn the blade height adjustment screw clockwise.
- To make the blade lower, turn the blade height adjustment screw anti-clockwise. Then tighten the blade height locking screw.

(Turn the screw while pushing the blade down with a cotton swab.)

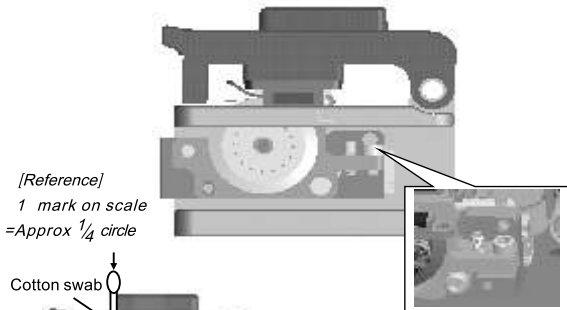

[Reference]
 1 mark on scale
 = Approx 1/4 circle

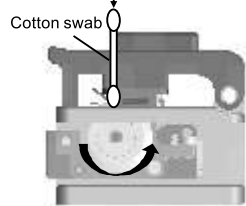

To make the blade lower, turn the blade height adjustment screw anti-clockwise, while pushing the blade down with a cotton swab.

- 4: Turn the blade height adjustment screw clockwise by more 1/4 to 1/2 circles from the reference point.

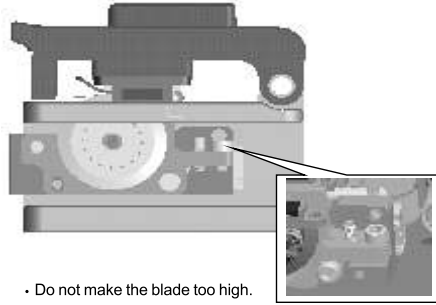

- Do not make the blade too high. Doing so will damage the anvil and increases the chipped fiber ends.

- 5: Tighten the blade height locking screw.

[Reference] Optimum torque: Approx. 0.59N.m (6kgf.cm)

- 6: Tighten the 2 cross head screws.

[Reference] Optimum torque: Approx. 0.98N.m (10kgf.cm)

Blade replacement

(0: For S2, S3, remove the right trim cover first)

- 1: Unscrew the blade setscrew.



部件

- 2: Remove the blade with tweezers. Do not make the blade hit other parts of the unit.

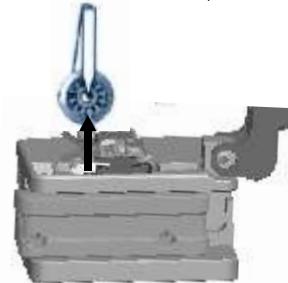

- The edge of a blade is manufactured precisely. If the edge is hit against metallic objects, it will crack, resulting in poor cleaving performance. Handle with care.
- When using metallic tweezers, be careful not to damage the blade.
- Do not touch the blade with hands. Use gloves.
- Dispose of the old blade properly.



- 3: Insert a new blade in the cleaver so that "1" of the number sticker is in the top position. Place the blade on the fixed surface of the blade fixing plate and gently push it into the groove. The hole of the blade should be aligned with the hole of the blade receptacle.

Enlarged view

"1" should be in the top position

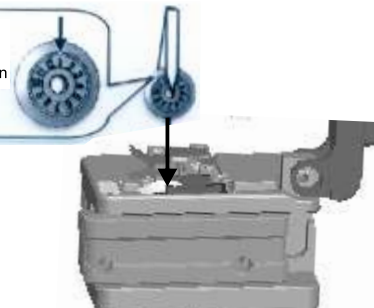

- 4: Tighten the blade setscrew completely, while pressing the side of the blade.
 [Reference] Optimum torque: Approx. 0.98N.m (10kgf.cm)



- 5: Adjust the blade height, referring to "Blade height adjustment" at page 2.
 6: Install the right trim cover after adjustment.

Troubleshooting



Good



Poor cleave angle



Lip



Crack

If the cleaving problem occurs, the followings are possible causes.

- (A) The fiber is placed obliquely in the cleaver.
 → Make sure that the fiber is placed straight in the cleaver.
- (B) The blade height is too high.
 → Adjust the blade height.
- (C) Dust or dirt remains on the blade
 → Clean the blade
- (D) Dust or dirt remains on the blade.
 → Clean the blade.
- (E) Dust or dirt remains on the fiber.
 → Remove the fiber coating and clean the bare fiber again.
 → The transportation process may cause up and down clamps do not compact optical fiber

If the problem still persists, please contact our maintenance service center.

Leveling method

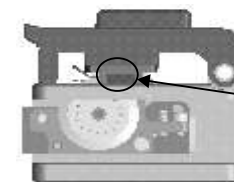

S2, S3

Align upper and lower clamps

The transportation process may cause upper and lower clamps cannot compact optical fiber.

There are gaps between upper and lower clamps.

- A. Firstly, remove the fiber clamp and then loosen the 2 internal hexagonal screws of connector.
- B. Align upper and lower clamps and clench them. (If there are no gaps between upper and lower clamps, tighten the 2 internal hexagonal screws.)
- C. Hold the entire machine facing the light at different angles to see if there is no gap between the clamps. If there is no gap, users can continue to cleave. Or users continue trying step A and B.